

SI50×150-CA

SI80×50-FA









SID80×50

SI63×150

Cylinder Sizing

- SI
- SI A.
- SC/ SU
- SCT
- SC A.
- DSN
- DSN A.
- MA
- MAL
- MA/MA A.
- SDA
- CQ2
- CJ2
- CDU
- TN
- CXS
- MGP
- MSQ

Ordering Code

SI	D	50	50	25	LB	MT
Series	Series Code	Bore	Stroke	Adjustable Stroke	Mountings	Sensor
SI: ISO 15552 Standard cylinder 	Blank: Standard double acting D: Double-shaft double acting 	32 40 50 63 80 100 125			Blank: Basic mountings LB: Front and back mounting  FA: Front mounting flange FB: Rear mounting flange  CA: Rear clevis (Single earring)  CB: Rear hinge (Double earring)  YB: Rear hinge 	JEL-30 type 

*All SI series standard cylinder are with magnet.

Specification

Bore (mm)	32	40	50	63	80	100	125
Operation	Double Acting						
Working Medium	Air						
Mountings	Basic FA FB CA CB LB YB						
Operating Pressure Range	1 ~ 9.0 Kg/cm ²						
Proof Pressure	13.5 Kg/cm ²						
Operating Temperature Range	0 ~ 70 °C						
Operating Speed Range	50 ~ 800 mm/s						
Cushion	Adjustable Cushioning						
Adjustable Cushioning Stroke	20 mm					26 mm	
Port Size	G 1/8"	G 1/4"		G 3/8"		G 1/2"	

SI Series

Standard Cylinder (Conforms to ISO15552 Standard)



The way to automation

- Cylinder
- Sizing
- SI
- SI A.
- SC / SU
- SCT
- SC A.
- DSN
- DSN A.
- MA
- MAL
- MA/MAL A.
- SDA
- CQ2
- CJ2
- CDU
- TN
- CXS
- MGP
- MSQ

Stroke

Bore	Standard Stroke	Max. Stroke	Allowable Stroke
32	25 50 75 80 100 125 150 160 175 200 250 300 350 400 450 500	1000	2000
40	25 50 75 80 100 125 150 160 175 200 250 300 350 400 450 500 600 700 800	1200	2000
50	25 50 75 80 100 125 150 160 175 200 250 300 350 400 450 500 600 700 800 900 1000	1200	2000
63	25 50 75 80 100 125 150 160 175 200 250 300 350 400 450 500 600 700 800 900 1000	1500	2000
80	25 50 75 80 100 125 150 160 175 200 250 300 350 400 450 500 600 700 800 900 1000	1500	2000
100	25 50 75 80 100 125 150 160 175 200 250 300 350 400 450 500 600 700 800 900 1000	1500	2000
125	25 50 75 80 100 125 150 160 175 200 250 300 350 400 450 500 600 700 800 900 1000	1500	2000

Internal Structure

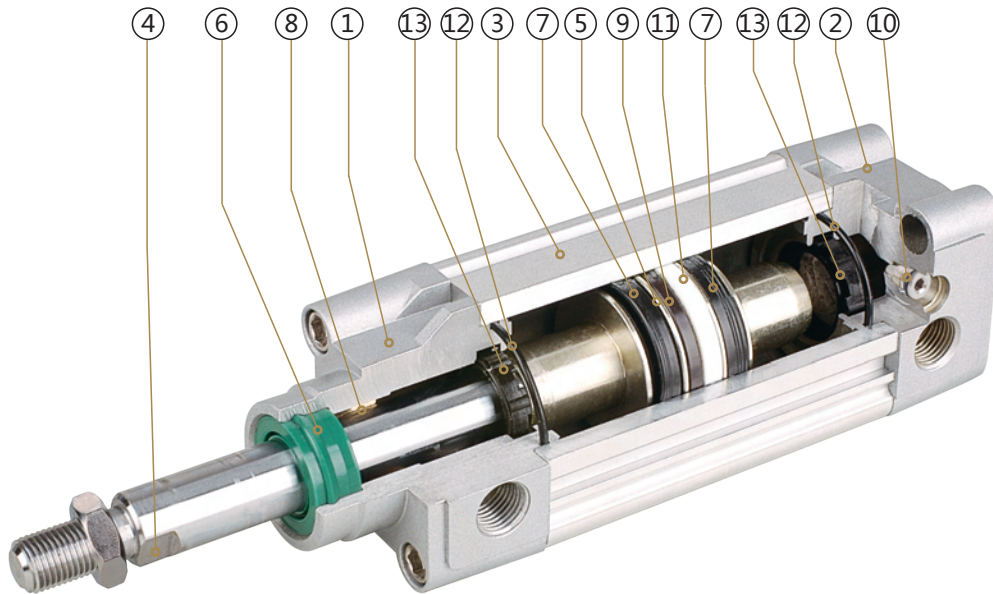

Parts

Number	Name	Material	Quantity
1	Front Cover	Painted Aluminium	1
2	Back Cover	Painted Aluminium	1
3	Barrel	Hard Anodised Aluminium	1
4	Piston Rod	Chromed Carbon Steel	1
5	Piston	Aluminium	1
6	Piston Rod Seal	Polyurethane	1
7	Piston Seal	NBR	2
8	Bearing	Non-lub Bearing	1
9	Magnet	Plastic	1
10	Cushion Screw	Brass	2
11	Anti-friction Ring	PTFE	1
12	End cap Seal	NBR	2
13	Cushion Seal	NBR	2

Overall Dimension

SI

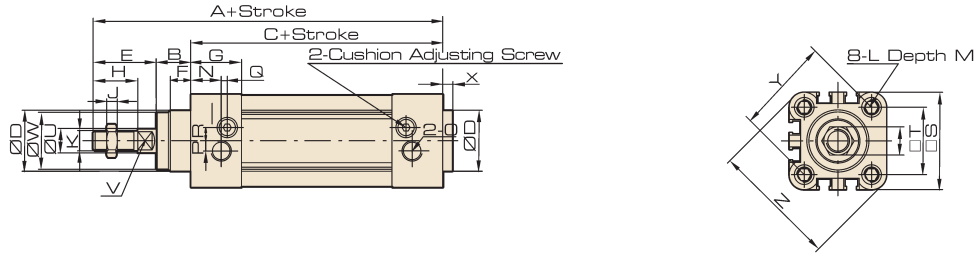

SID

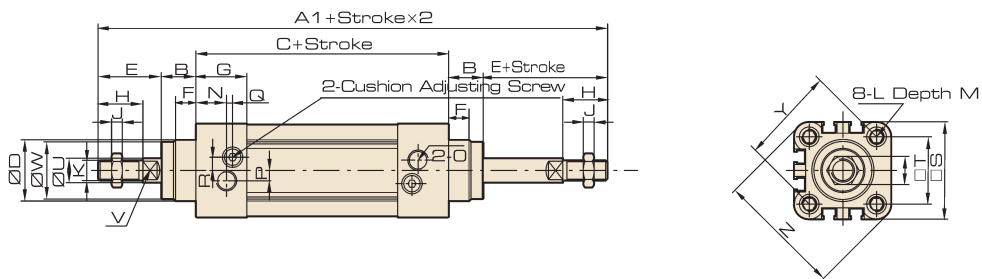

SIJ

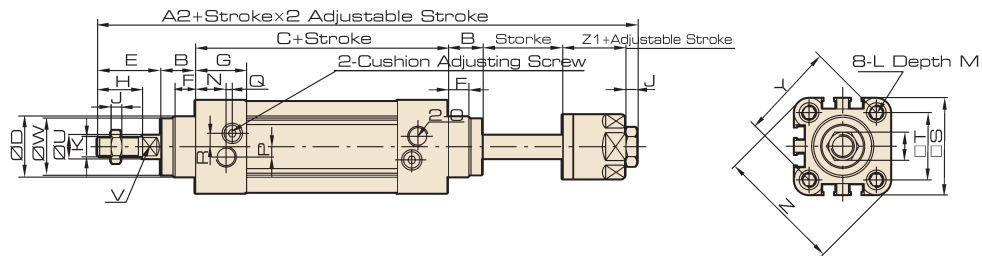

Cylinder Sizing

- SI
- SI A.
- SC / SU
- SCT
- SC A.
- DSN
- DSN A.
- MA
- MAL
- MA/MA A.
- SDA
- CQ2
- CJ2
- CDU
- TN
- CXS
- MGP
- MSQ

Dimension

Bore/ Symbol	A	A1	A2	B	C	D	E	F	G	H	I	J	K	L
32	142	190	185	16	94	30	33	10	25	22	17	6	M10 x 1.25	M6
40	159	213	207	20	105	35	34	10	29.5	24	17	7	M12 x 1.25	M6
50	175	244	233	27	106	40	42.5	10	32	32	23	8	M16 x 1.5	M8
63	190	258	247	26	122	45	42	10	36	32	23	8	M16 x 1.5	M8
80	214	301	288	35	127	45	53	10	37	40	26	10	M20 x 1.5	M10
100	229	321	308	40	137	55	52	10	39	40	26	10	M20 x 1.5	M10
125	277	394	378	46	160	60	71	10	43.5	54	40	10	M27 x 2	M12

Bore/ Symbol	M	N	O	P	Q	R	S	T	U	V	W	X	Y	Z	Z1
32	12	15	G 1/8	5	3	6.5	45	32.5	12	10	28	4	46	58.7	21
40	12	17.5	G 1/4	7	3	7	52	38	16	13	33	4	53.7	68	21
50	12	20	G 1/4	7	3	9	65	46.5	20	17	38	4	65.8	84.5	23
63	12	22	G 3/8	8	5	9	76	56.5	20	17	38	4	79.9	99.6	23
80	15	23	G 3/8	10	5	12	94	72	25	22	43.5	5	101.8	123.8	29
100	15	26	G 1/2	10	5	14	112	89	25	22	47	6	125.9	148.9	29
125	20	29	G 1/2	10	5	14	134	110	32	27	53	7	156.9	179.6	40.5

SI Series

Standard Cylinder Accessory (Conforms to ISO15552 Standard)



The way to automation

- Cylinder
- Sizing
- SI
- SI A.
- SC / SU
- SCT
- SC A.
- DSN
- DSN A.
- MA
- MAL
- MA/MAL A.
- SDA
- CQ2
- CJ2
- CDU
- TN
- CXS
- MGP
- MSQ

LB Foot

Overall Dimension

LB

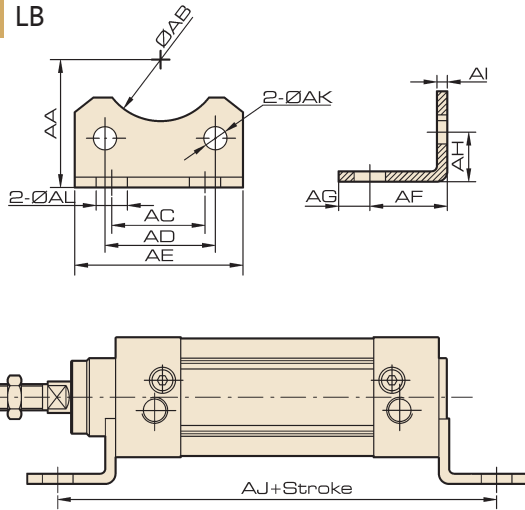

Dimension

Bore / Symbol	32	40	50	63	80	100	125
AA	32	36	45	50	63	71	90
AB	30	35	40	45	45	55	60
AC	32	36	45	50	63	75	90
AD	32.5	38	46.5	56.5	72	89	110
AE	46.5	52.5	65	75	94.5	114.5	140
AF	24	28	32	32	41	41	45
AG	9	11	11	14	14	16	18
AH	15.8	17	21.8	21.8	27	26.5	35
AI	3.2	3.2	3.2	3.6	4.5	4.5	8
AJ	142	161	170	185	210	220	250
AK	6.5	6.5	8.5	8.5	10.5	10.5	12.5
AL	7	10	10	10	12	14.5	16.5

FA / FB Flange

Overall Dimension

FA , FB

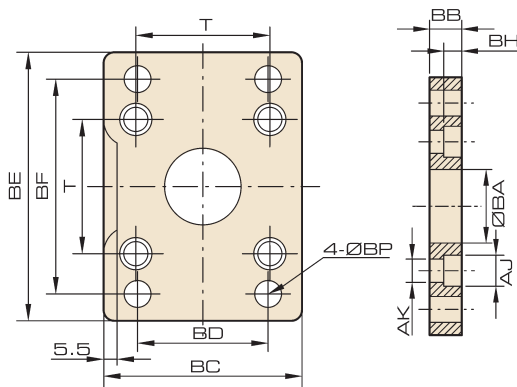

Dimension

Bore / Symbol	32	40	50	63	80	100	125
BA	30.3	35.3	40.3	45.3	45.3	55.3	60.3
BB	10	10	12	12	16	16	20
BC	45	52	65	76	94	112	140
BD	32	36	45	50	63	75	90
BE	80	90	110	120	150	175	224
BF	64	72	90	100	126	150	180
BH	6.5	6.5	8.5	8.5	10.5	10.5	15
AJ	10.5	10.5	13.5	13.5	16.5	16.5	19
AK	6.5	6.5	8.5	8.5	10.5	10.5	12.5
BP	7	9	9	9	12	14	16
T	32.5	38	46.5	56.5	72	89	110

CA Hinge

Overall Dimension

Dimension

CA

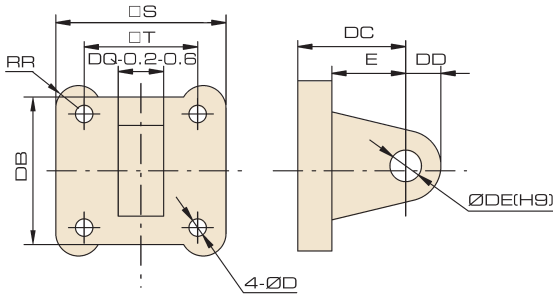

Bore/ Symbol	32	40	50	63	80	100	125
S	45	52	65	76	94	112	140
T	32.5	38	46.5	56.5	72	89	110
RR	6.5	6.5	9	9.5	11	11.5	12
DB	34	41	54	65	83	101	123
DC	22	25	27	32	36	41	50
DD	10	11	13	16	16	20	25
DE	10	12	12	16	16	20	25
DQ	26	28	32	40	50	60	70
D	6.5	6.5	8.5	8.5	10.5	10.5	12.5
E	14	17	17	22	24	25	30

CB Hinge

CB

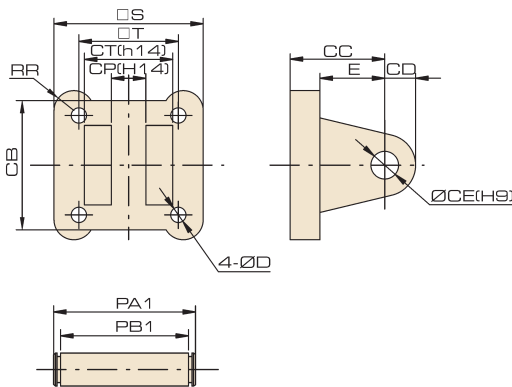

Bore/ Symbol	32	40	50	63	80	100	125
S	45	52	65	76	94	112	140
T	32.5	38	46.5	56.5	72	89	110
D	6.5	6.5	8.5	8.5	10.5	10.5	12.5
E	14	17	17	22	24	25	30
RR	6.5	6.5	9	9.5	11	11.5	12
CB	34	41	54	65	83	101	123
CC	22	25	27	32	36	41	50
CD	10	11	13	16	16	20	25
CE	10	12	12	16	16	20	25
CP	26	28	32	40	50	60	70
CT	45	52	60	70	90	110	120
PA1	53	60	68	78	100	120	130
PB1	46.5	53.5	61.5	71.5	91.5	111.5	121.5

YB Hinge

YB

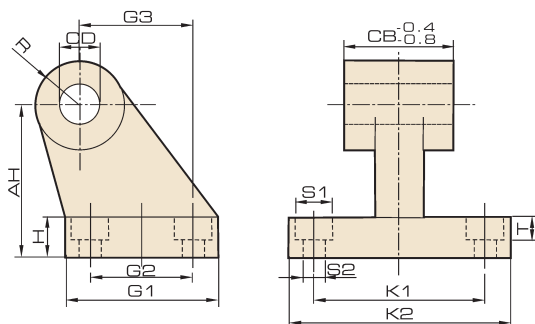

Bore/ Symbol	32	40	50	63	80	100	125
AH	32	36	45	50	63	71	90
H	8	10	12	12	14	15	20
CD	10	12	12	16	16	20	25
G1	31	35	45	50	60	70	90
G2	18	22	30	35	40	50	60
G3	21	24	33	37	47	55	70
CB	26	28	32	40	50	60	70
K1	38	41	50	52	66	76	94
K2	51	54	65	67	86	96	124
S1	11	11	14	14	17	17	20
S2	6.6	6.6	9	9	11	11	14
T	1.6	1.6	1.6	1.6	2.5	2.5	3.2
R	10	11	13	15	15	19	22.5