

VF, VZ Series Solenoid Valve

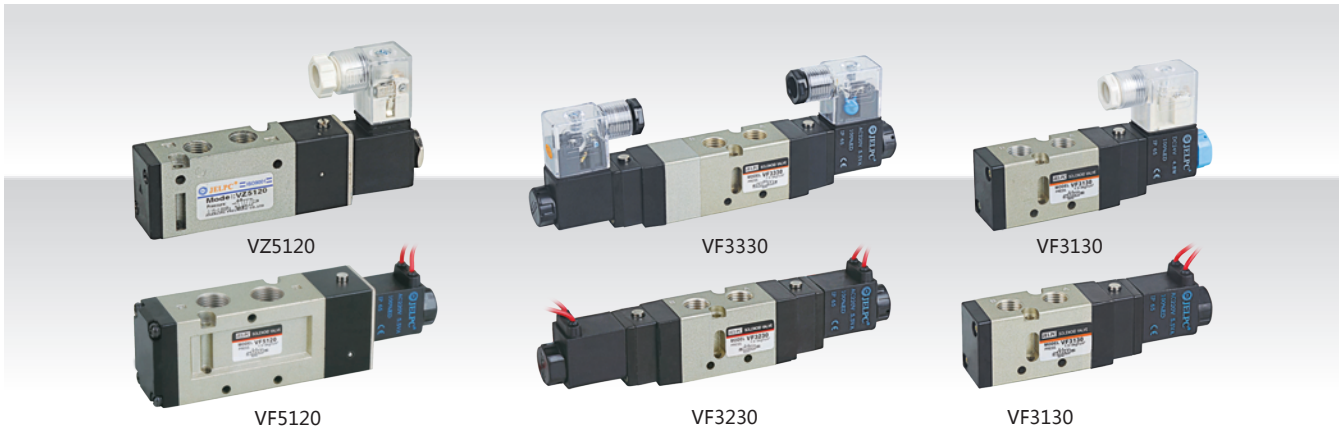

The way to automation

- Valve
- 4V100
- 4V200
- 4V300
- 4V400
- Manifold
- 3V1
- JEL
- JZF
- MVSD
- VF, VZ**
- BM, PU, AM
- Diaphragm
- Coil
- 2V
- 2W
- 2W(Big)
- 2P
- 2L
- VX
- PU
- PU225
- 2Q
- JEL5404
- JEL6213
- Pulse
- JELJZF
- 4H
- TSV
- MPV
- 4HV
- HV, K
- 4R
- 4F
- MSV
- JM
- ASC, RE
- QE, QEA
- ST
- HSV



Ordering Code

VF3	1	30	AC110V	W	F
Series	Coil and Initial Status	Ordering Number	Standard Voltage	Wiring	Joint
VF3 Series	1: Single coil	VF3: 30	DC12V DC24V	Blank: Without light indicator	1 F-20 F
VF5 Series	2: Double coil	VF5: 20	AC24V 50Hz/60Hz	LD: Brown with light indicator	
VZ5 Series	3: Mid-position Closed	VZ5: 20	AC110V 50Hz/60Hz	LD1: White with light indicator	
	4: Mid-position Open		AC220V 50Hz/60Hz	W: Lead wire	
	5: Mid-position Exhaust		AC380V 50Hz/60Hz		

Specification

Model	VF3130	VF3230	VF33(4/5)30	VF5120	VF5220	VF53(4/5)50	VZ5120	VZ5220	VZ53(4/5)50
Valve Type	5/2 way		5/3 way	5/2 way		5/3 way	5/2 way		5/3 way
Effective Cross Section Area	16 mm ² (CV = 0.89)	12mm ² (CV=0.67)	25 mm ² (CV = 1.40)	18 mm ² (CV=1.00)		12 mm ² (CV = 0.67)	9 mm ² (CV=0.50)		
Working Medium	40 Micron Filtered Air								
Operation	Internal Piloted								
Working-pressure	0.15 ~ 0.8 MPa								
Max. Test Pressure	1.2 MPa								
Ambient Temperature	5 ~ 50 °C								
Operating Voltage Tolerance	± 10%								
Power Consumption	AC: 5.5 VA DC: 4.8 W								
Protect Class	F Class, IP 65								
Wiring / Connector	Cable / Lead Wire or DIN Connector								
Switching Frequency	5 Cycles / Sec.								
Response Time	0.05 Sec.								

Base Ordering Code

VF3000M	□F
Series	Joint Base Number
VF3000M : VF3 Series	VF3000M : 1~20 F
VF5000M : VF5 Series	VF5000M : 1~20 F
VZ5000M : VZ5 Series	VZ5000M : 1~20 F

Overall Dimension

VF3130

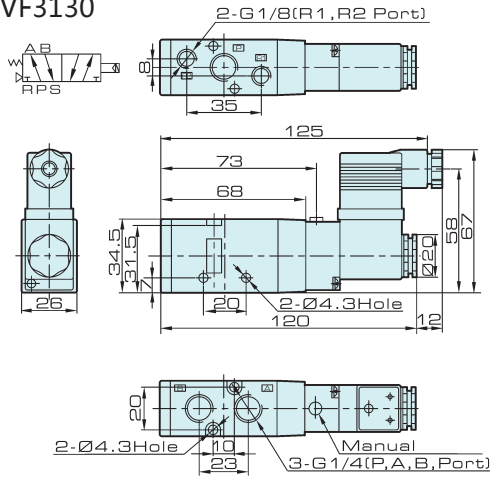

VF3230

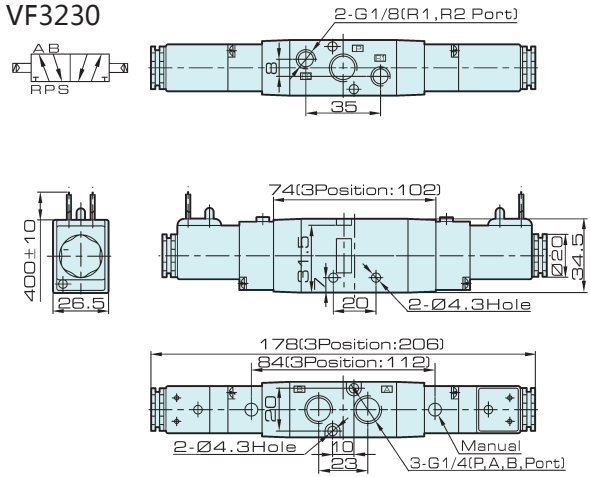

VF5120

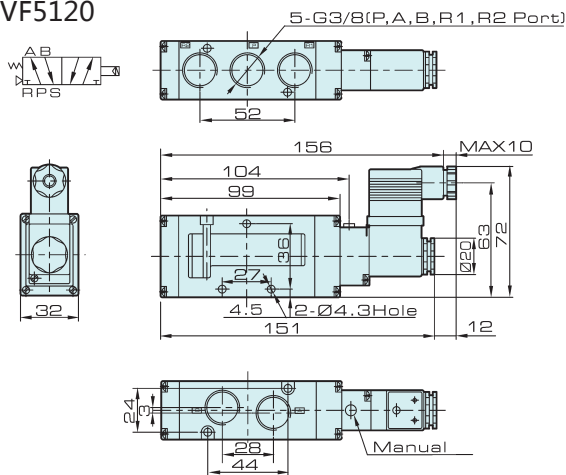

VF5220

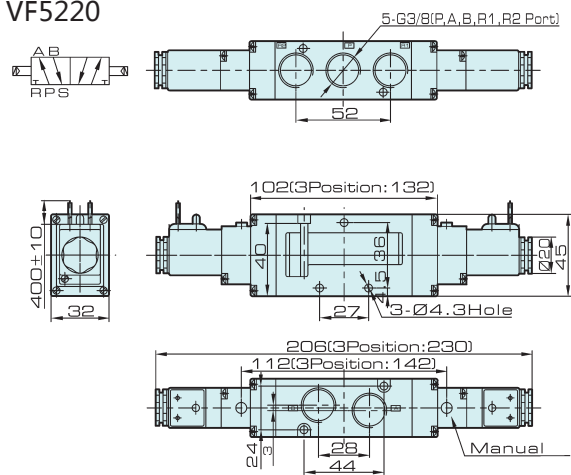

VZ5120

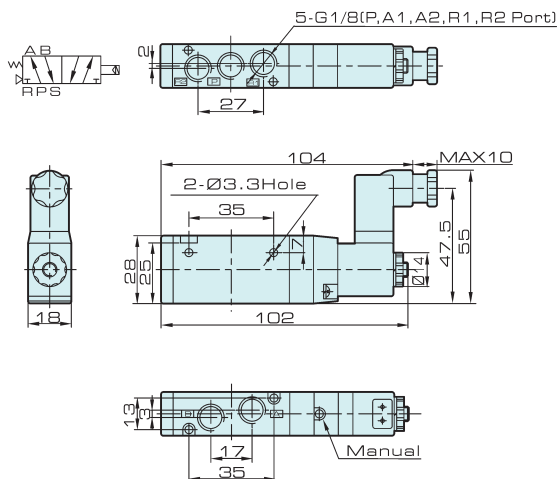

VZ5220

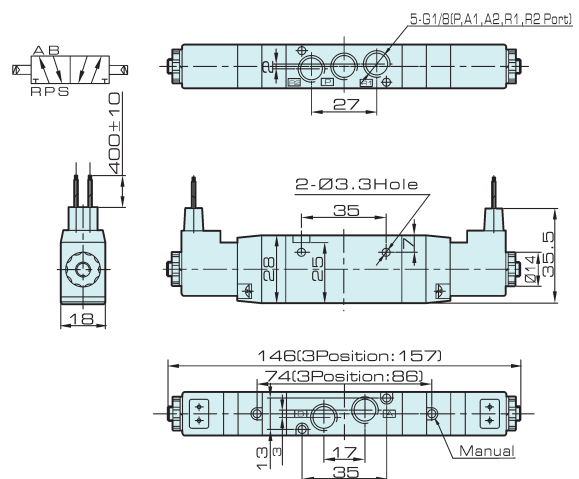

Valve

4V100
4V200
4V300
4V400

Manifold

3V1
JEL
JZF
MVSD
VF, VZ

BM, PU, AM

Diaphragm

Coil

2V
2W
2W(Big)
2P

2L

VX

PU

PU225

2Q

JEL5404

JEL6213

Pulse

JEL, JZF

4H

TSV86

MPV

4HV

HV, K

4R

4F

MSV

JM

ASC, RE

QE, QEA

ST

HSV

VF, VZ Series Solenoid Valve



The way to automation

- Valve
- 4V100
- 4V200
- 4V300
- 4V400
- Manifold
- 3V1
- JEL
- JZF
- MVSD
- VF, VZ**
- BM, PU, AM
- Diaphragm
- Coil
- 2V
- 2W
- 2W(Big)
- 2P
- 2L
- VX
- PU
- PU225
- 2Q
- JEL5404
- JEL6213
- Pulse
- JELJZF
- 4H
- TSV
- MPV
- 4HV
- HV, K
- 4R
- 4F
- MSV
- JM
- ASC, RE
- QE, QEA
- ST
- HSV

Overall Dimension

VF3000M

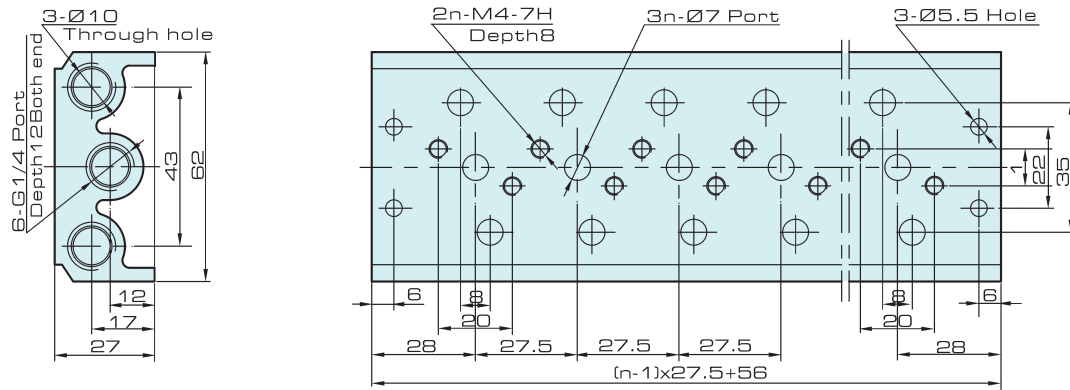

VF5000M

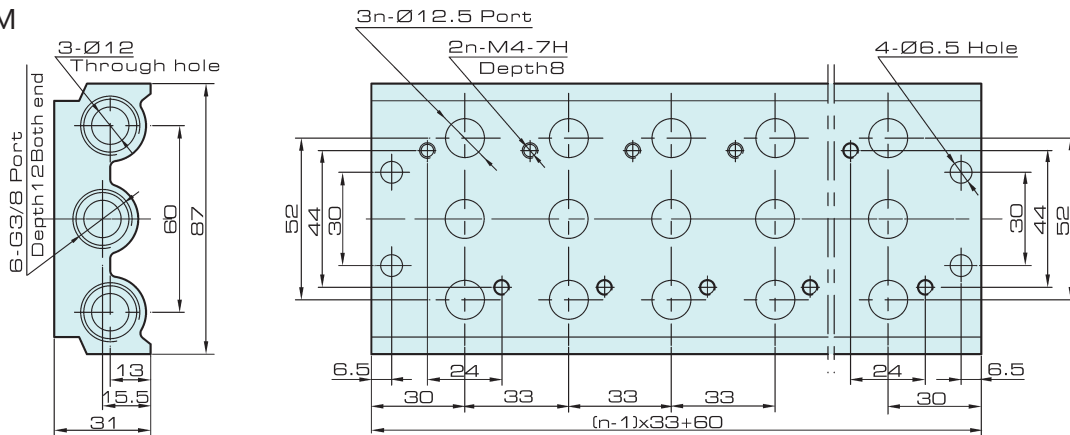

VZ5000M

