

# Sanlixin Solenoid Valve

## DF series pilot operated liquid solenoid valve

### Specifications

1	Max operation pressure: 8bar
2	Operating pressure differential: 0.3-8bar (φ3, φ5 Direct acting 0~6 bar)
3	Ambient temperature: -10℃-50℃
4	Fluid media temperature: 0℃-75℃
5	Voltage: AC:380V;220V;36V/50Hz DC:12V;24;110V;220V
6	Insulation class: F class
7	Power consumption: φ5-φ20 12w φ25-φ100 15w φ125-φ150 30w,
8	Coil temperature rising: -15% - 10%
9	Coil temperature rising: +10% to -10% applicable voltage
10	fluid media: liquids, air, light oil <20CST
11	Mounting position: flow as arrow, solenoid vertical and upright direction.
12	Response time: φ3~φ50≤1s Closed≤2s ; φ65~φ150≤3s Closed≤5s



### Parameters

Model code	A(mm)	H(mm)	Pipe size(Female Thread)	Body material	Weight(KG)
DF-15	90	105	G 1/2"	Brass	1.0
DF-20	100	115	G 3/4"		1.2
DF-25	120	135	G 1"		1.6
DF-32	135	145	G 1 1/4"		2.1
DF-40	145	160	G 1 1/2"		2.7
DF-50	185	180	G 2"		4.3

### Construction, external dimensions chart

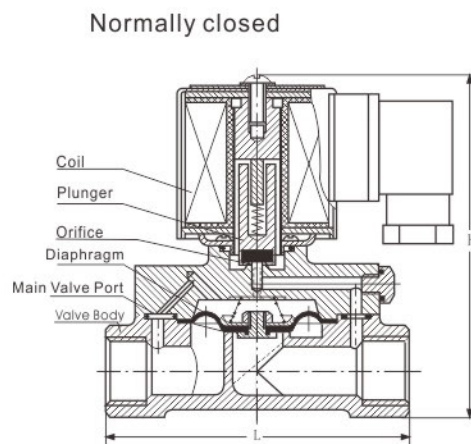

If you want the valve normally open model for example:DF-15H



# **DF series pilot operated liquid solenoid valve**



## **Construction Dimensions Chart**

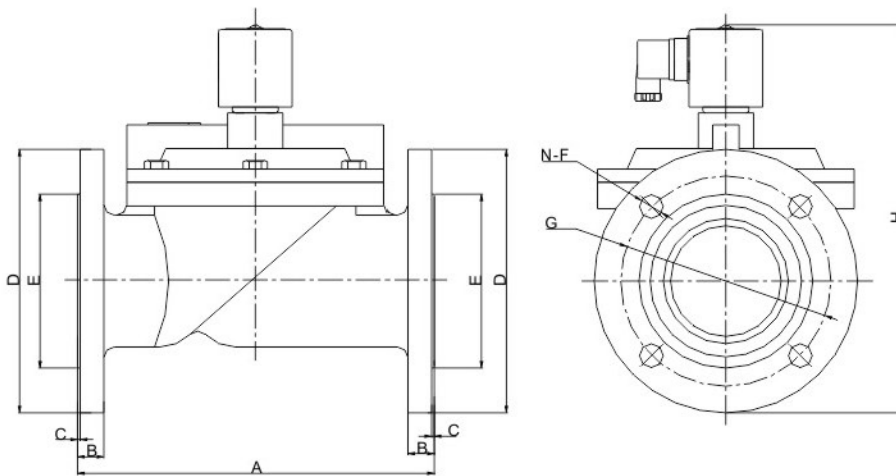

Model	A	B	C	ΦD	ΦE	ΦF	ΦG	H	N	Body Material
DF-40F	155	15	2	150	88	18	110	205	4	Cast Iron
DF-50F	200	16	2	160	88	18	125	220	4	
DF-65F	250	20	3	185	118	18	145	260	4	
DF-80F	270	18	2	200	132	18	160	275	4	
DF-100F	350	20	2	220	160	18	180	310	8	
DF-125F	400	25	3	250	184	18	210	380	8	
DF-150F	450	24	3	285	212	22	240	405	8	